

SERIE CR

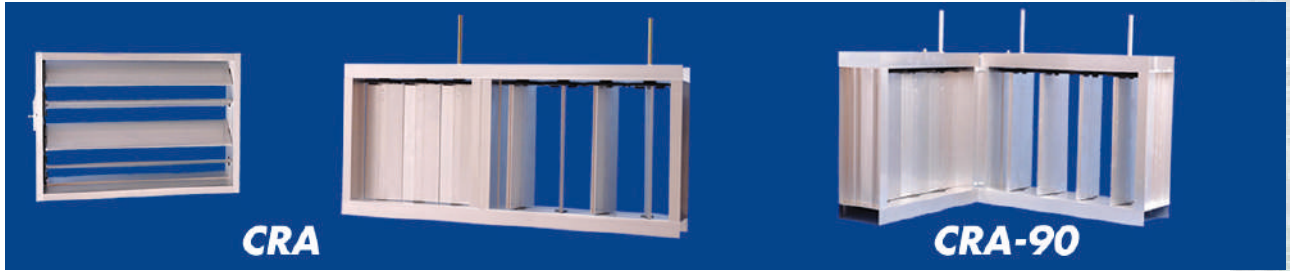

Compuerta de regulación.
Aletas aerodinámicas.
Aluminio extruido.
Accionamiento automático ó manual.

Control dampers.
Aerofoil blades section.
Extruded aluminium.
Electric or manual control options.

Clapets d'équilibrage.
Ailettes aérodynamiques.
Aluminium extrudé.
Accionnement automatique ou manuel.

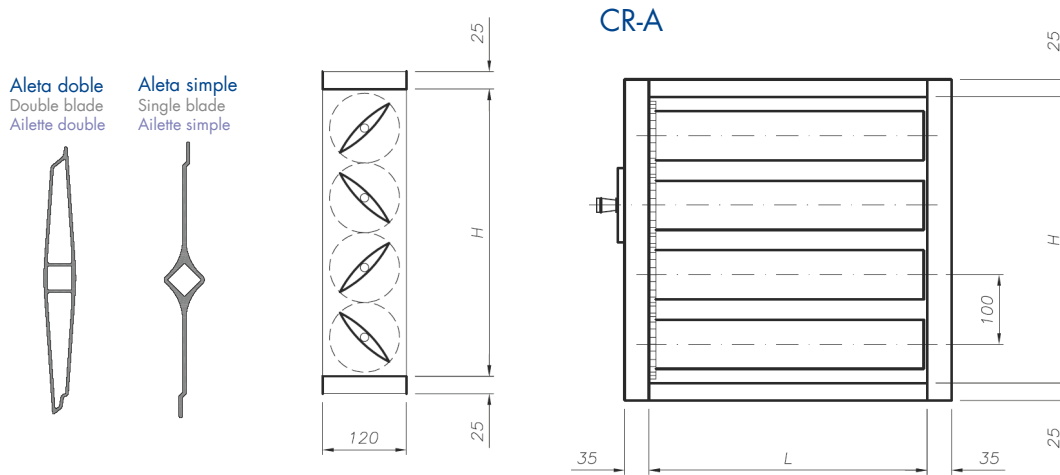

Ejecuciones especiales

Specials executions

Exécutions spéciales

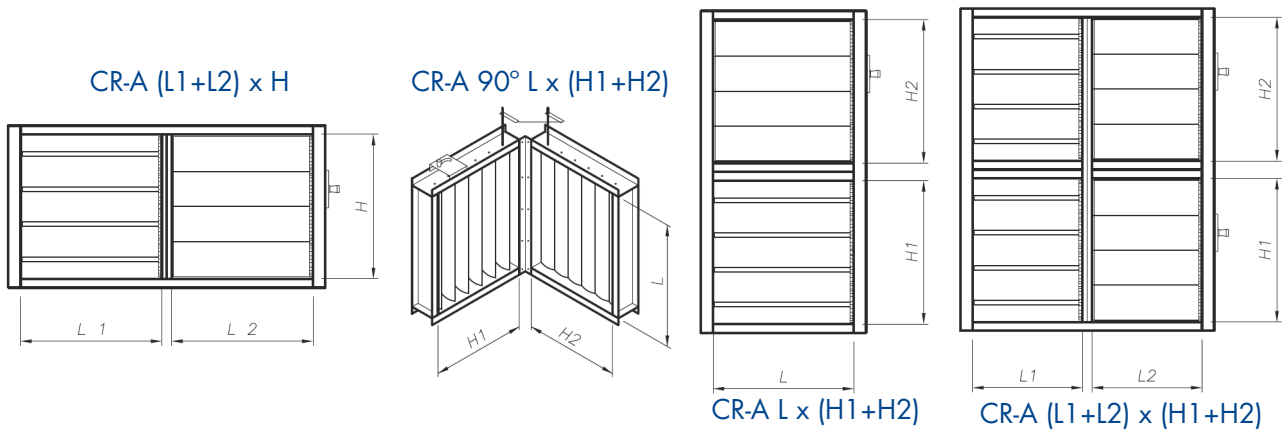

IDENTIFICACIÓN

IDENTIFICATION IDENTIFICATION

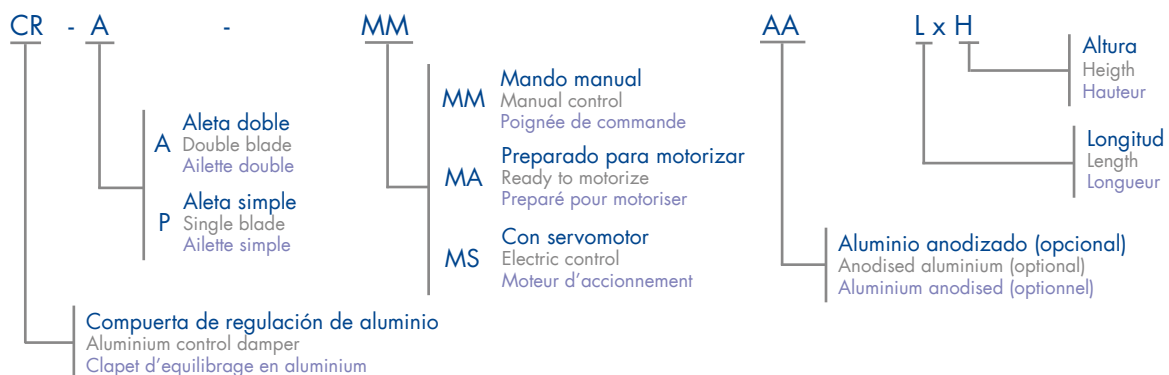

SERIE CR

TABLA DE SELECCIÓN

SELECTION TABLE TABLEAU DE SÉLECTION

| | | L | | | | | | | | | | | |
|--------------------------|---|------------------------------|------------------------------|------------------------------|------------------------------|------------------------------|------------------------------|------------------------------|------------------------------|------------------------------|------------------------------|------------------------------|------------------------------|
| H | 412 | 400 | 500 | 600 | 800 | 1.000 | 1.200 | 1.500 | 2.000 | | | | |
| | 512 | | 400 | 500 | 600 | 800 | 1.000 | 1.200 | 1.500 | 2.000 | | | |
| | 612 | | | 400 | 500 | 600 | 800 | 1.000 | 1.200 | 1.500 | 2.000 | | |
| | 812 | | | | 400 | 500 | 600 | 800 | 1.000 | 1.200 | 1.500 | 2.000 | |
| | 1.012 | | | | | 400 | 500 | 600 | 800 | 1.000 | 1.200 | 1.500 | 2.000 |
| Q | A _k | 0,160 m ² | 0,200 m ² | 0,250 m ² | 0,300 m ² | 0,400 m ² | 0,500 m ² | 0,600 m ² | 0,800 m ² | 1,000 m ² | 1,200 m ² | 1,600 m ² | 2,000 m ² |
| 1.000 m ³ /h | V _k ΔP L _{wA} | 1,7 m/s 2 Pa 16 dB(A) | 1,4 m/s 1 Pa 12 dB(A) | 1,1 m/s 1 Pa 8 dB(A) | | | | | | | | | |
| 2.000 m ³ /h | V _k ΔP L _{wA} | 3,5 m/s 6 Pa 33 dB(A) | 2,8 m/s 4 Pa 29 dB(A) | 2,2 m/s 2 Pa 24 dB(A) | 1,9 m/s 2 Pa 21 dB(A) | | | | | | | | |
| 3.000 m ³ /h | V _k ΔP L _{wA} | 5,2 m/s 14 Pa 43 dB(A) | 4,2 m/s 9 Pa 39 dB(A) | 3,3 m/s 6 Pa 34 dB(A) | 2,8 m/s 4 Pa 31 dB(A) | 2,1 m/s 2 Pa 25 dB(A) | | | | | | | |
| 4.000 m ³ /h | V _k ΔP L _{wA} | 6,9 m/s 24 Pa 50 dB(A) | 5,6 m/s 15 Pa 46 dB(A) | 4,4 m/s 10 Pa 41 dB(A) | 3,7 m/s 7 Pa 38 dB(A) | 2,8 m/s 4 Pa 32 dB(A) | 2,2 m/s 2 Pa 27 dB(A) | | | | | | |
| 5.000 m ³ /h | V _k ΔP L _{wA} | 8,7 m/s 38 Pa 56 dB(A) | 6,9 m/s 24 Pa 51 dB(A) | 5,6 m/s 15 Pa 47 dB(A) | 4,6 m/s 11 Pa 43 dB(A) | 3,5 m/s 6 Pa 37 dB(A) | 2,8 m/s 4 Pa 33 dB(A) | 2,3 m/s 3 Pa 29 dB(A) | 1,7 m/s 2 Pa 23 dB(A) | | | | |
| 6.000 m ³ /h | V _k ΔP L _{wA} | | 8,3 m/s 35 Pa 56 dB(A) | 6,7 m/s 22 Pa 51 dB(A) | 5,6 m/s 15 Pa 47 dB(A) | 4,2 m/s 9 Pa 42 dB(A) | 3,3 m/s 6 Pa 37 dB(A) | 2,8 m/s 4 Pa 34 dB(A) | 2,1 m/s 2 Pa 28 dB(A) | 1,7 m/s 1 Pa 23 dB(A) | | | |
| 8.000 m ³ /h | V _k ΔP L _{wA} | | | 8,9 m/s 40 Pa 58 dB(A) | 7,4 m/s 27 Pa 54 dB(A) | 5,6 m/s 15 Pa 49 dB(A) | 4,4 m/s 10 Pa 44 dB(A) | 3,7 m/s 7 Pa 41 dB(A) | 2,8 m/s 4 Pa 35 dB(A) | 2,2 m/s 2 Pa 30 dB(A) | 1,9 m/s 2 Pa 27 dB(A) | 1,4 m/s 1 Pa 21 dB(A) | |
| 10.000 m ³ /h | V _k ΔP L _{wA} | | | | 9,3 m/s 43 Pa 60 dB(A) | 6,9 m/s 24 Pa 54 dB(A) | 5,6 m/s 15 Pa 50 dB(A) | 4,6 m/s 11 Pa 46 dB(A) | 3,5 m/s 6 Pa 40 dB(A) | 2,8 m/s 4 Pa 36 dB(A) | 2,3 m/s 3 Pa 32 dB(A) | 1,7 m/s 2 Pa 26 dB(A) | 1,4 m/s 1 Pa 22 dB(A) |
| 12.500 m ³ /h | V _k ΔP L _{wA} | | | | | 8,7 m/s 38 Pa 60 dB(A) | 6,9 m/s 24 Pa 55 dB(A) | 5,8 m/s 17 Pa 51 dB(A) | 4,3 m/s 9 Pa 46 dB(A) | 3,5 m/s 6 Pa 41 dB(A) | 2,9 m/s 4 Pa 38 dB(A) | 2,2 m/s 2 Pa 32 dB(A) | 1,7 m/s 2 Pa 27 dB(A) |
| 15.000 m ³ /h | V _k ΔP L _{wA} | | | | | | 8,3 m/s 35 Pa 60 dB(A) | 6,9 m/s 24 Pa 56 dB(A) | 5,2 m/s 14 Pa 50 dB(A) | 4,2 m/s 9 Pa 46 dB(A) | 3,5 m/s 6 Pa 42 dB(A) | 2,6 m/s 3 Pa 36 dB(A) | 2,1 m/s 2 Pa 32 dB(A) |
| 17.500 m ³ /h | V _k ΔP L _{wA} | | | | | | 9,7 m/s 47 Pa 63 dB(A) | 8,1 m/s 33 Pa 60 dB(A) | 6,1 m/s 18 Pa 54 dB(A) | 4,9 m/s 12 Pa 49 dB(A) | 4,1 m/s 8 Pa 46 dB(A) | 3,0 m/s 5 Pa 40 dB(A) | 2,4 m/s 3 Pa 36 dB(A) |
| 20.000 m ³ /h | V _k ΔP L _{wA} | | | | | | | 9,3 m/s 43 Pa 63 dB(A) | 6,9 m/s 24 Pa 57 dB(A) | 5,6 m/s 15 Pa 53 dB(A) | 4,6 m/s 11 Pa 49 dB(A) | 3,5 m/s 6 Pa 43 dB(A) | 2,8 m/s 4 Pa 39 dB(A) |
| 25.000 m ³ /h | V _k ΔP L _{wA} | | | | | | | | 8,7 m/s 38 Pa 63 dB(A) | 6,9 m/s 24 Pa 58 dB(A) | 5,8 m/s 17 Pa 54 dB(A) | 4,3 m/s 9 Pa 49 dB(A) | 3,5 m/s 6 Pa 44 dB(A) |
| 30.000 m ³ /h | V _k ΔP L _{wA} | | | | | | | | | 8,3 m/s 35 Pa 63 dB(A) | 6,9 m/s 24 Pa 59 dB(A) | 5,2 m/s 14 Pa 53 dB(A) | 4,2 m/s 9 Pa 49 dB(A) |
| 40.000 m ³ /h | V _k ΔP L _{wA} | | | | | | | | | | 9,3 m/s 43 Pa 66 dB(A) | 6,9 m/s 24 Pa 60 dB(A) | 5,6 m/s 15 Pa 56 dB(A) |

| | | | |
|--------------------------|---------------------------------|----------------------------------|----------------------------------|
| Q | Caudal (m ³ /h) | Airflow (m ³ /h) | Débit (m ³ /h) |
| ΔP | Pérdida de presión (Pa) | Pressure loss (Pa) | Perte de charge (Pa) |
| L_{wA}(A) | Potencia sonora (dB(A)) | Sound power level (dB(A)) | Puissance sonore (dB(A)) |
| V_k | Velocidad efectiva (m/sg) | Effective velocity (m/sg) | Vitesse effective (m/sg) |
| A_k | Área efectiva (m ²) | Effective area (m ²) | Aire effective (m ²) |

| |
|-------------|
| < 35 dB(A) |
| 35/45 dB(A) |
| 45/55 dB(A) |
| > 55 dB(A) |

| Apertura de aletas Vanes opening / Ouverture de ailettes | FΔP | FL _{wA} (A) |
|---|-------|----------------------|
| 100% | x 1 | + 0 dB(A) |
| 75% | x 8 | + 6 dB(A) |
| 50% | x 100 | + 25 dB(A) |
| 25% | x 440 | + 55 dB(A) |

La apertura de las aletas modifica la pérdida de carga y la potencia sonora de la compuerta según los factores que se detallan en la siguiente tabla:

The vanes opening modifies the pressure loss and the sound power level of the damper according to the factor that are detailed in the following table:

L'ouverture des ailettes modifie la perte de charge et la puissance sonore de l'unité suivant les facteurs qui apparaissent ci dessous.